

Monochrome laser multifunction product



## Lexmark MX417de



MX417de

**Combines 4 devices into 1. With more speed and capacity.**

Affordability meets higher speed and output capacity in the MX417de multifunction product, which prints up to 38 pages per minute and is recommended for printing up to 10,000 pages per month. It includes a 10.9cm (4.3 inch) colour touch screen to simplify tasks, keypad, built-in Gigabit networking and advanced security, along with available High Yield cartridges and mobile print capability.\*

**Multifunction versatility with increased speed and capacity**

Now you can achieve more in less time. Improve your print, scan and copy speeds with a dual-core processor, 512MB of memory (upgrades up to 2.5GB) and Gigabit networking. The compact and reliable MX417de can print up to 38 pages per minute and deliver the first page in as little as 6.5 seconds.



Up to 38 ppm



Network



Duplex



Unison Toner



Security



Mobility



10.9 cm touchscreen

**Security, with Confidential Print. Mobile print capability.**

Extensive network security features and protocols protect your device, information and network from unauthorized access. Keep your sensitive documents safe by enabling the Confidential Print feature, which requires entering a customised, unique PIN on the device's keypad before the document can be printed.

Print from mobile devices using an optional Wi-Fi adapter or Lexmark's free Mobile Print app.



### 4-year Guarantee

Given the choice, wouldn't you prefer to buy a device that protects your investment with a guarantee? The affordable MX417de is so well made, we back it with a guarantee that covers repair actions including the cost of spare parts if they are needed in the first four years\*\*. The guarantee also offers you free 24-hour online support and access to technical support by phone during working hours.

\*Requires free Lexmark Mobile Print app with Android or iOS mobile device

\*\*Offer applies if the product is registered within 90 days from the date of purchase. Supplies and/or consumable parts, such as fuser or transfer unit, are excluded. Please refer to the detailed terms and conditions available at [lexmark.com/myguarantee](http://lexmark.com/myguarantee).

### High Yield cartridges offer lower cost per page

The MX417de can use available High Yield cartridges to produce up to 8,500 pages, which helps lower your cost per page. Plus they never require shaking, which minimises interruptions and keeps your work moving. Lexmark's print system and exclusive Unison™ Toner ensure consistent print quality throughout the life of the cartridge to prevent wasted prints.

### User-friendly

The MX417de features a 10.9 cm (4.3 inch) customizable color touch screen that provides quick access to copy, fax and scan functions. It also provides access to pre-installed applications, such as our Forms and Favorites app that lets you save frequently used documents and print them from the touch screen.

Monitor jobs and supplies on the screen, or from a remote location through its web interface. Add an extra paper tray to boost capacity to 850 pages for fewer interruptions. A front USB port lets you print directly from a flash drive.

The MX417de is built to last, so you'll easily be able to print up to 10,000 pages per month, thanks to our state-of-the-art paper handling technology.

An automatic document feeder simplifies printing, copying, scanning and faxing multipage documents.

### Eco-friendly

Built-in two-sided printing reduces paper use. The instant warm-up fuser saves energy and delivers the first page as fast as 6.5 seconds. Select an energy-saving mode (Quiet, Hibernate or Eco) to automatically minimize noise and energy consumption.

Through LCCP, the Lexmark Cartridge Collection Program, Lexmark offers a free and easy way for you to return your empty cartridges for sustainable recycling or remanufacturing. Learn more at <http://www.lexmark-emea.com/LCCP/recycling>



Product specifications		Lexmark MX417de
<b>Print</b>		
Display	Lexmark e-Task 4.3-inch (10.9 cm) colour touch screen	
Print Speed: Up to <sup>6</sup>	Black: 38 ppm	
Time to First Page: As fast as	Black: 6.5 seconds	
Print Resolution	Black: 1200 Image Quality, 1200 x 1200 dpi, 2400 Image Quality, 600 x 600 dpi	
Memory / Processor	Standard: 512 MB / Maximum: 2560 MB / Dual Core, 800 MHz	
Hard Disk	Not Available	
Recommended Monthly Page Volume <sup>2</sup>	750 - 10000 pages	
Maximum Monthly Duty Cycle: Up to <sup>3</sup>	100000 pages per month	
<b>Copy</b>		
Copy Speed: Up to <sup>6</sup>	Black: 38 cpm	
Time to First Copy: as fast as	Black: 6.5 seconds	
<b>Scan</b>		
Scanner Type / ADF Scan	Flatbed scanner with ADF / RADF (reversing Duplex)	
A4/Ltr Duplex Scan Speed: Up to	Black: 18 / 19 sides per minute / Colour: 8 / 8 sides per minute	
A4/Ltr Simplex Scan Speed: Up to	Black: 42 / 43 sides per minute / Colour: 19 / 20 sides per minute	
ADF Paper Input Capacity: Up to	50 pages 75 gsm bond	
<b>Fax</b>		
Modem Speed	ITU T.30, V.34 Half-Duplex, 33.6 Kbps	
<b>Supplies<sup>7</sup></b>		
Laser Cartridge Yields (up to) <sup>1</sup>	2,500-page Cartridge, 8,500-page High Yield Cartridge	
Imaging Unit Estimated Yield: Up to	60000 pages, based on 3 average letter/A4-size pages per print job and ~ 5% coverage	
Cartridge(s) Shipping with Product <sup>1</sup>	2,500-page Starter Return Program Toner Cartridge	
<b>Paper Handling</b>		
Included Paper Handling	250-Sheet Input, 50-Sheet Multipurpose Feeder, 150-Sheet Output Bin, Integrated Duplex	
Optional Paper Handling	250-Sheet Tray, 550-Sheet Tray, 550-Sheet Lockable Tray	
Paper Input Capacity: Up to	Standard: 300 pages 75 gsm bond / Maximum: 850 pages 75 gsm bond	
Paper Output Capacity: Up to	Standard: 150 pages 75 gsm bond / Maximum: 150 pages 75 gsm bond	
Media Types Supported	Card Stock, Envelopes, Paper Labels, Plain Paper, Transparencies, Refer to the Card Stock & Label Guide.	
Media Sizes Supported	10 Envelope, 7 3/4 Envelope, 9 Envelope, A4, A5, DL Envelope, Executive, Folio, JIS-B5, Legal, Letter, Statement, Universal, Oficio, A6	
<b>General Information<sup>4</sup></b>		
Standard Connectivity	USB 2.0 Specification Hi-Speed Certified (Type B), Gigabit Ethernet (10/100/1000), Front USB 2.0 Specification Hi-Speed Certified port (Type A)	
Optional Network Ports	MarkNet N8352 802.11b/g/n Wireless	
Noise Level: Operating	Print: 55 dBA / Copy: 55 dBA / Scan: 55 dBA	
Specified Operating Environment	Temperature: 16 to 32°C (60 to 90°F), Humidity: 8 to 80% Relative Humidity, Altitude: 0 - 2896 Meters (9,500 Feet)	
Product Guarantee	4 Years Guarantee SMB Line	
Size (mm - H x W x D) / Weight	468 x 399 x 472 mm / 20.0 kg	

<sup>1</sup>Average standard page yield value declared in accordance with ISO/IEC 19752. <sup>2</sup>"Recommended Monthly Page Volume" is a range of pages that helps customers evaluate Lexmark's product offerings based on the average number of pages customers plan to print on the device each month. Lexmark recommends that the number of pages per month be within the stated range for optimum device performance, based on factors including: supplies replacement intervals, paper loading intervals, speed, and typical customer usage. <sup>3</sup>"Maximum Monthly Duty Cycle" is defined as the maximum number of pages a device could deliver in a month using a multishift operation. This metric provides a comparison of robustness in relation to other Lexmark printers and MFPs. <sup>4</sup>Printers are sold subject to certain license/agreement conditions. See [www.lexmark.com/printerlicense](http://www.lexmark.com/printerlicense) for details. <sup>5</sup>Actual Yield may vary based on other factors such as device speed, paper size and feed orientation, toner coverage, tray source, percentage of black-only printing and average print job complexity. <sup>6</sup>Print and copy speeds measured in accordance with ISO/IEC 24734 and ISO/IEC 24735 respectively (ESAT). For more information see: [www.lexmark.com/ISOspeeds](http://www.lexmark.com/ISOspeeds). <sup>7</sup>Product functions only with replacement cartridges designed for use in a specific geographical region. See [www.lexmark.com/regions](http://www.lexmark.com/regions) for more details.

## Lexmark MX417de features

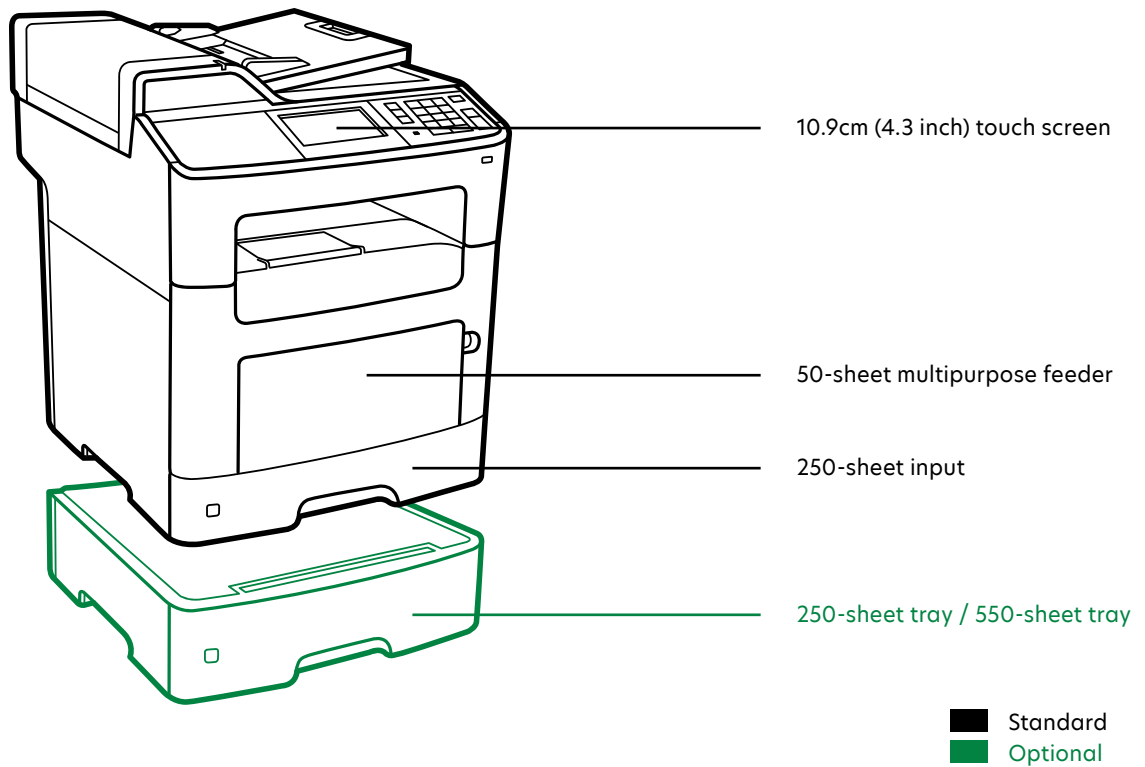

© 2017 Lexmark. All rights reserved.

Lexmark and the Lexmark logo are trademarks or registered trademarks of Lexmark International, Inc. in the United States and/or other countries. All other trademarks are the property of their respective owners. ENERGY STAR® is a U.S. registered mark.